



PANIC AND FIRE EXIT HARDWARE

OVERVIEW

In accordance with Section 1008.1.9 of the Uniform Statewide Building Code (USBC) and Statewide Fire Prevention code (SFPC), each door in a means of egress from a group A or E occupancy having an occupant load of 50 or more, and Group H occupancy, and certain sized and rated electrical rooms, shall not be provided with a lock or latch unless it is panic hardware or fire exit hardware. For buildings built prior to 2006 edition of the USBC, this hardware was required for assembly for educational occupancies having an occupant load of 100 or more.

APPROVED PANIC HARDWARE

The USBC and SFPC require that panic hardware consist of a door-latching assembly incorporating an activating device (typically a horizontal bar or push pad) that causes the door to unlatch when a force is applied in the direction of egress travel. Approved panic hardware must meet the following specifications:

1. Have a maximum unlatching force of 15 pounds and be capable of on-handed operation without special effort or knowledge.
2. On standard swinging exit doors the activating portion of the releasing device shall extend at least one-half ($\frac{1}{2}$) the width of the door length (see example below).
3. On balanced exit doors the activating device must be of the push-pad type and shall **not** extend more than one-half ($\frac{1}{2}$) the width of the door leaf from the latch side.
4. The activating device must be mounted at a height greater than 34 inches but less than 48 inches above the finished floor.

Note: Some panic hardware devices labeled as “Listed Panic Hardware” or “Listed Panic Device” may not meet the specifications required by the USBC and SFPC. For example, devices having small push-pads or paddles not extending at least one-half the width of the door leaf would not meet the requirements for approved panic hardware.

TYPICAL PANIC HARDWARE

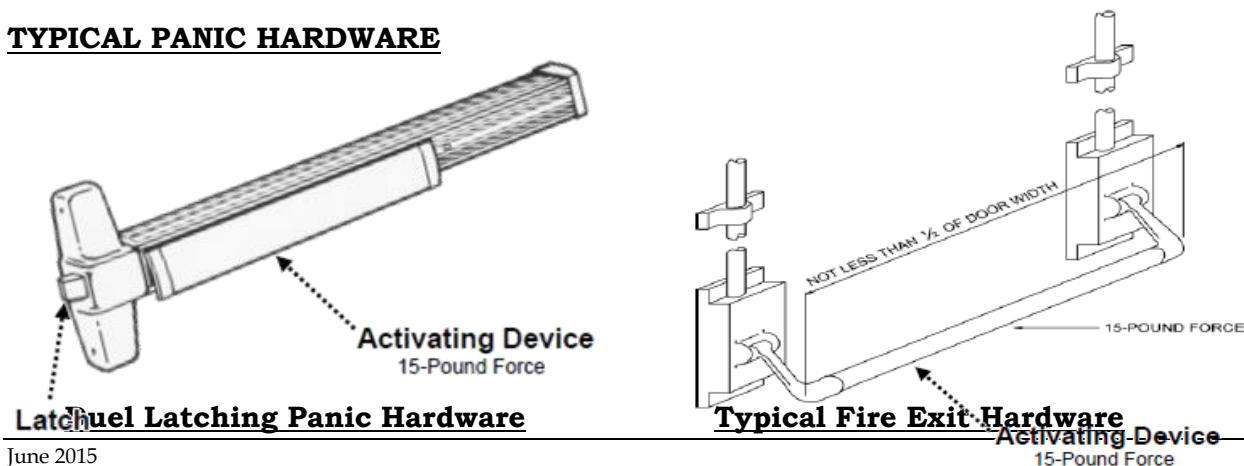

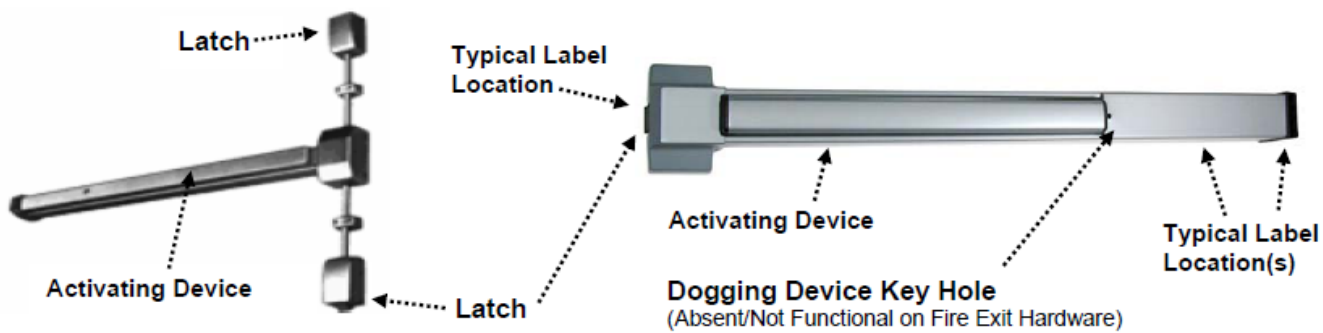

FIRE EXIT HARDWARE

Where fire door assemblies are required to have panic hardware, approved fire exit hardware shall be provided. Fire exit hardware is approved panic hardware which has also been tested and certified for use on swinging fire door assemblies. Fire door assemblies are defined by the USBC and SFPC as a combination of the fire door(s), frame, hardware, and other accessories required to provide a specific degree of fire and smoke barrier protection to the opening in a fire wall, fire partition, or fire-rated barrier where a doorway is located.

Swinging fire doors must be closed and positively latched to protect exit stairways, corridors, and other areas of the building from the spread of smoke and fire. Additionally, swinging fire doors are required to self-close and automatically latch after each use. Positive latching of swinging fire doors is not related to the locking of the door and should never be confused with locking or security issues.

Because swinging fire doors are required to positively latch, “dogging devices” are not permitted on fire exit hardware. A dogging device mechanically defeats the latching feature of panic hardware preventing the door from positively latching when in the closed position. The dogging device is typically manually activated with a small wrench or tool. A dogging feature is found only on standard panic hardware which should never be used on a fire door assembly.

Fire exit hardware must be labeled. The contents of the label must include the words “Listed” and “Fire Exit Hardware” and indicate a control or serial number. The label on the fire door itself should indicate that it is a fire door suitable for use with fire exit hardware.

Note: Standard panic hardware or “Listed Panic Hardware” is **not** approved for use on fire door assemblies. Panic hardware and fire exit hardware can be similar in appearance. Prior to purchase of installation of fire exit hardware, be sure you understand these differences and look for the correct label type and the absence of a dogging device.

Questions about the content of this publication should be directed to the Fire Marshal’s Office at 540-662-2298, Monday through Friday, 8:00 a.m. to 5:00 p.m.